

# Technical Specification and Connector Description of IGEL-UD 3 Series (Model: IGEL-M310C)

CAUTION: Standard deployment of the device is in vertical position, horizontal deployment only supported with optional rubber feet!

## 1.

### Specification

<b>Processor</b>	VIA Nano U3500 1GHz
<b>Chipsets</b>	VIA VX855
<b>Memory</b>	DDR2 533-800 SO-DIMM x 1 (up to 2 GB)
<b>Audio</b>	VIA VT1708S HD
<b>Network</b>	10/100/1000Mbps Ethernet (RJ45 connector)
<b>USB</b>	5 x USB 2.0
<b>Storage</b>	One 1*44 pins IDE port / One 1*50 pins CF port
<b>BIOS</b>	4MB LPC ROM Award PnP
<b>Power</b>	DC in 12V/3A 36W External Power Adapter (Elementech AU1361203N) DC in 12V/4A 48W External Power Adapter (Elementech AU-799IN-L5)
<b>Dimension (DxWxH)</b>	203.1mm x 47.5mm x 191.1mm (without foot stand) 226.9mm x 81.5mm x 231.2mm (with foot stand)

## 2.

### Front View

Item	Description
1	Smartcard Reader slot (Smartcard Reader optional)
2	Power button
3	Cover (Line out / Mic in jacks; 1 x USB 2.0 port)
4	Foot stand (optional with WLAN support VIA VT6656)

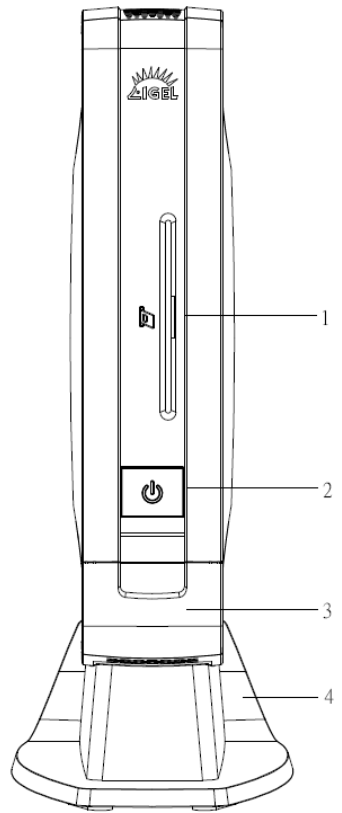

## 3.

### Rear View

Item	Description
1	PS/2 keyboard connector
2	10/100/1000 Base-T Ethernet RJ45 port
3	USB 2.0 ports
4	DVI-I port (VGA via adapter)
5	COM1 serial port
6	DC power jack, 12V DC in

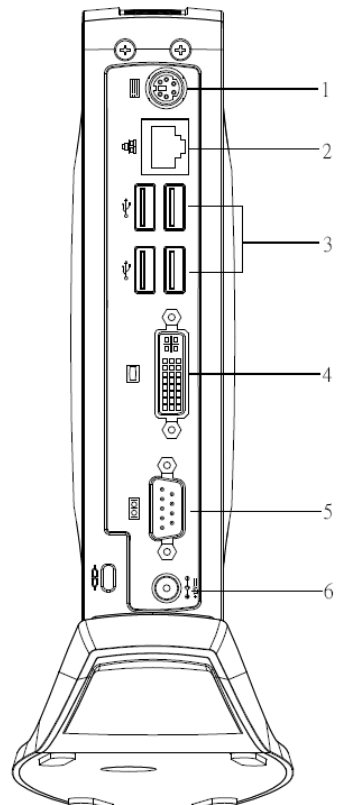

## Energy Star Note

IGEL Thin Clients with a Microsoft® Windows® Embedded Standard or Linux operating system have been shipped enabled for power management. The display Sleep mode will be activated after 15 minutes of user inactivity (default setting). The standby settings can be managed via the BIOS and local setup. The activation from the standby or Off mode can be done locally (by moving of the mouse or pressing a key on the key board) and via the Ethernet connection (Wake-On-LAN).

## Energy Star Program

Power managing your ENERGY STAR qualified computer can save up to 340 kWh annually or 25€ (\$35) per year. These energy savings are equivalent to:

- Preventing over 225 kg (500 lbs) of CO2 emissions per year
- Planting over 185 m<sup>2</sup> (2,000 sq ft.) of forest

To learn how to power manage your computers at your office all at once through network solutions, please go to: [www.energystar.gov/powermanagement](http://www.energystar.gov/powermanagement)

ENERGY STAR is the government-backed program that helps us all save money and protect our environment with energy-efficient products and practices (see [www.energystar.gov](http://www.energystar.gov) / <http://www.eu-energystar.org>).

## FCC Note

This equipment has been tested and found to comply with the limits for a Class B digital device, pursuant to Part 15 of the FCC rules. These limits are designed to provide reasonable protection against harmful interference in a residential installation. This equipment generates, uses and can radiated radio frequency energy and, if not installed and used in accordance with the instructions, may cause harmful interference to radio communications. However, there is no guarantee that interference will not occur in a particular installation. If this equipment does cause harmful interference to radio or television reception, which can be determined by turning the equipment off and on, the user is encouraged to try to correct the interference by one or more of the following measures:

- Reorient or relocate the receiving antenna.
- Increase the separation between the equipment and receiver.
- Connect the equipment into an outlet on a circuit different from that to which the receiver is connected.
- Consult the dealer or an experienced radio/TV technician for help.

Shielded interface cables must be used in order to comply with emission limits.

Changes or modifications not expressly approved by the party responsible for compliance could void the user's authority to operate the equipment.

## R&TTE Directive Note and Restriction of Use

For the case of using the optional available "Connectivity Foot type 2 for UD3 models" which supports Wireless LAN functionality by the factory installed Wireless module type VIA VNT6656G6A40, IGEL Technology declares that the product complies with the requirements of the R&TTE directive 1999/5/EC.

**The Wireless LAN functionality is restricted to indoor use only.**

## WEEE and Battery Waste Note

### Removal of old units and batteries by IGEL – to protect the environment.

In accordance with EU directive 2002/96/EC on Waste Electrical and Electronic Equipment (WEEE) and Directive 2006/66/EC for waste batteries, customers and manufacturers are responsible for returning and recycling their old equipment and batteries. IGEL now offers a convenient return service.

As of August 15, 2005, all IGEL Thin Clients sold bear the WEEE and battery waste seal. All Thin Clients labelled with this sticker are taken back and disposed of immediately at no charge (including the battery). For IGEL customers, this means better service and greater convenience, because IGEL Technology handles the professional recycling of all Thin Clients (including the lithium battery).

Report disposal online: Under the heading, "Waste Management WEEE" on the IGEL Homepage ([www.igel.com](http://www.igel.com)) there is an online form that must be filled in for the old IGEL units to be picked up. Such information as the address, series number, contact person, number of units to be removed and the desired disposal date are urgently required for the smooth processing of waste.

Pickup: Immediately after sending in your data, you will receive from the IGEL Service Center a notice of confirmation of receipt. Then an IGEL service employee will contact you to arrange a date to pick up the unit.

IGEL WEEE Number: DE 79295479

## RoHS and REACH Note

This product of IGEL Technology GmbH fulfils the requirements of the EU directive 2002/95/EC on the Restriction of the Use of certain Hazardous Substances in Electrical and Electronic Equipment (RoHS). The product is marked accordingly.

The EU Regulation 1907/2006 for Registration, Evaluation, Authorisation and restriction of Chemicals (REACH) shall improve the protection of human health and the environment from the risks that can be posed by chemicals. IGEL fulfils this regulation by informing customers and partners about materials on the Candidate List of Substances of Very High Concern (SVHC) in our products in a concentration above 0.1 % weight by weight (w/w). Current information about SVHC materials can be found at <http://www.igel.com/int/reach>.

## Copyright

### Copyright 2006-2011 Publishing. All Rights Reserved.

This manual, software and firmware described in it are copyrighted by their respective owners and protected under the laws of the Universal Copyright Convention. You may not reproduce, transmit, transcribe, store in a retrieval system, or translate into any language, in any form or by any means, electronic, mechanical, magnetic, optical, chemical, biological, molecular, manual, or otherwise, any part of this publication without the express written permission of the publisher.

All products and trade names described within are mentioned for identification purpose only. No affiliation with or endorsement of the manufacturer is made or implied. Product names and brands appearing in this manual are registered trademarks of their respective companies. The information published herein has been checked for accuracy as of publishing time. No representation or warranties regarding the fitness of this document for any use are made or implied by the publisher. We reserve the right to revise this document or make changes in the specifications of the product described therein at any time without notice and without obligation to notify any person of such revision or change. Shielded interface cables must be used in order to comply with emission limits. Changes or modifications not expressly approved by the party responsible for compliance could void the user's authority to operate the equipment.

